

# **N** **NORTHERN<sup>®</sup> PUMP**

Division of McNally Industries, LLC

## **Heavy Duty Gear Pumps**

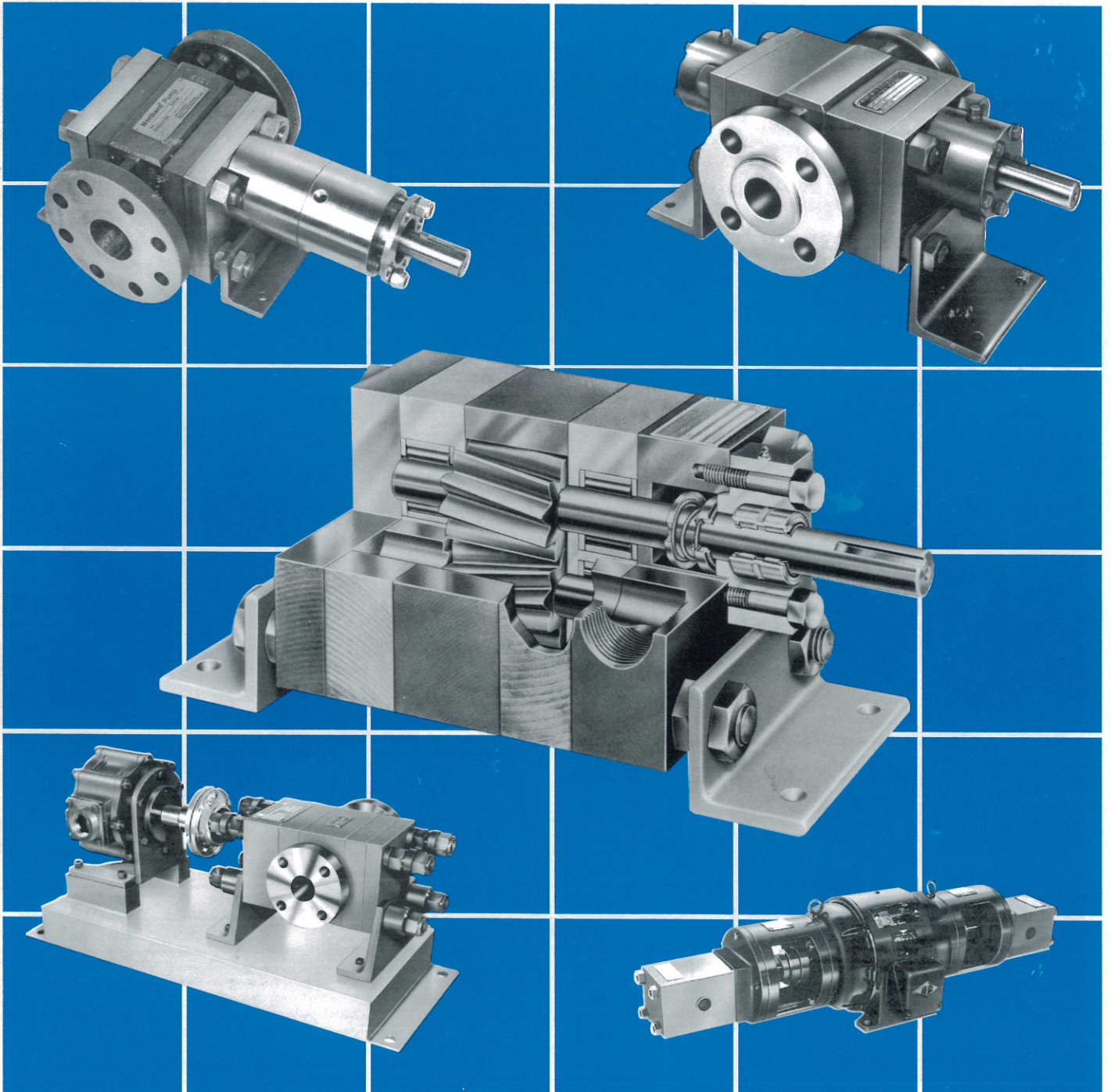

# Heavy duty gear pumps factory-engineered for your application –

**VISCOSITY RANGE: 0.5 TO 1,500,000 cP**  
**TEMPERATURE RANGE: -65° F TO 850° F**  
**INLET CAPACITY: 28" Hg lift to 1200 psig**

Northern gear pumps described in this catalog are positive displacement rotary gear pumps. They are designed for nearly any liquid transfer application, particularly those involving extremes of temperature, viscosity, pressure and inlet conditions. The exceptions are liquids containing high concentrations of abrasives, liquids which have poor lubricity such as water, and liquids that are corrosive.

As with any gear pump, the life of a Northern gear pump applied to fluid

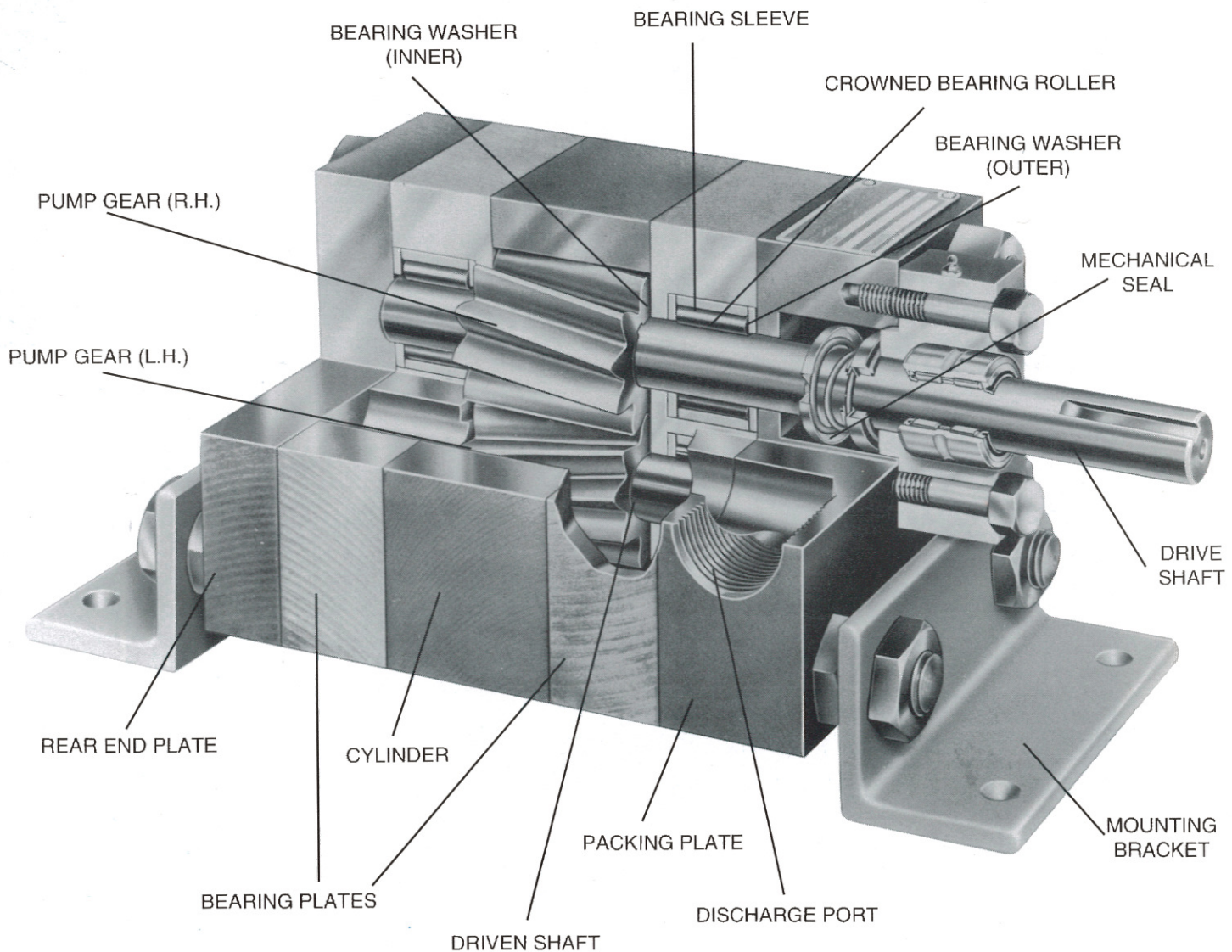

transfer is dependent on the lubricity of the liquid. Indeed, the degree to which a Northern gear pump will tolerate liquids with limited lubricity is often a key factor in its selection over other gear pumps. This tolerance is achieved by careful choice of materials, precision machining, and when required, custom designing to best suit the application. Beyond this, prior to shipment every Northern gear pump is tested under conditions simulated to match the conditions of the intended application. This includes

viscosity, speed, discharge pressure and inlet conditions. Then GPM delivered and horsepower required are verified.

You'll find Northern gear pumps built to meet exacting requirements in nearly every industry, pumping diverse materials such as tar, molten lead, peanut butter, adhesives and hot polymers. For eight decades, Northern Pump has been building reliable gear pumps to handle the industry's toughest applications.

**FOR COMPLETE INFORMATION**

Request a Northern Heavy Duty Gear Pump Catalog 39 which contains complete performance data on all standard pumps. Also included are useful formulas and conversion factors. All data is given in both U.S. Customary and SI Metric Figures.

**Northern Pump**

Division of McNally Industries, LLC  
 340 W. Benson Avenue  
 Grantsburg, WI 54840  
 (715) 463-5177 (800) 366-1410  
 Fax (715) 463-5174  
 E-Mail: info@northern-pump.com  
 Website: www.northern-pump.com

**BASIC FEATURES**

1. **GEARS** – Nitride hardened to tool steel hardness (equivalent to 65-68 Rockwell C), then ground after heat treating to achieve a precision gear tooth form. Extreme hardness offers greater resistance to wear when pumping liquids with low lubricity. Helical configuration assures smooth, quiet performance.
2. **SHAFTS** – Carburized steel or nitrided, hardened and ground. Through-shaft available for hydraulic balancing of high inlet pressures, or for driving a second pump.
3. **BEARINGS** – Large, full complement contour roller-type bearings assure even distribution of bearing load. Optional sleeve bearings are available in carbon graphite, nitrided steel, bronze, and other special materials.
4. **MECHANICAL SEALS** – Standard pumps offer mechanical seals for inlet pressures from vacuum to 25 psig. Optional mechanical seal configurations are available for inlet pressures to 1200 psig. Packings are available for applications not suited to mechanical seals.
5. **PLATES** – Cast iron cylinder and bearing plates, and steel end and packing plates are standard. All plates have mating surfaces precision machined to seal without conventional gaskets. Steel bearing plates with inlays of bronze, iron or other special materials are available.
6. **CYLINDER** – Cast iron cylinder is standard. When an all-steel housing is required, a steel cylinder with cast iron liner or bronze is furnished.
7. **SUCTION AND DISCHARGE PORTS** – Choice of screwed pipe threads or flanged openings (see Dimension Data, page 4).
8. **MOUNTING BRACKETS** – Angle brackets illustrated at left are standard (see Dimensional Data, page 4). Special brackets for elevation to driver shaft, and flanges for horizontal or vertical mounting are available. Mounting holes may also be tapped directly into pump case to eliminate brackets.
9. **MAINTENANCE** – Northern gear pumps can usually be serviced in your plant. Modular design lends itself to easy disassembly and reassembly when and if any parts need replacing.

**STANDARD SPECIFICATIONS**

PUMP SERIES	GPM AT O DIFF. PRESS. AND 1750 RPM	RPM MAX.	DIFFERENTIAL PRESSURE, MAX.
4300	.36	3450	2000
	4.65	1750	300
4400	2.82	3450	1800
	17.0	1750	300
4500	4.43	3450	2000
	26.6	1750	300
4600	10.2	3450	2000
	81.4	1750	250
4800	36.0	1750	1500
	216.0	1750	250
4900	43.2 @ 1150 RPM	1150	2000
	216.3 @ 1150 RPM	1150	400

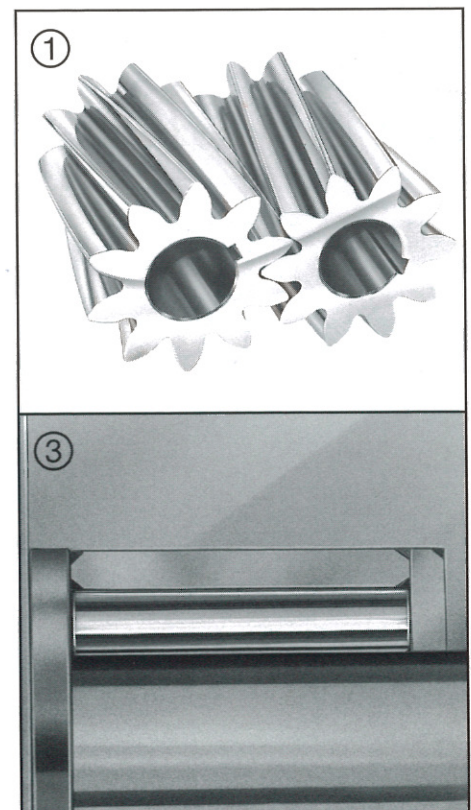

# DIMENSION DATA – MODEL 4300

Pump Size	A	B	C
4300-01	6.82	3.98	6.91
4300-02	6.89	4.05	6.99
4300-03	6.99	4.15	7.09
4300-04	7.09	4.25	7.19
4300-06	7.29	4.45	7.39
4300-08	7.49	4.65	7.59
4300-10	7.69	4.85	7.79
4300-12	7.89	5.05	7.99

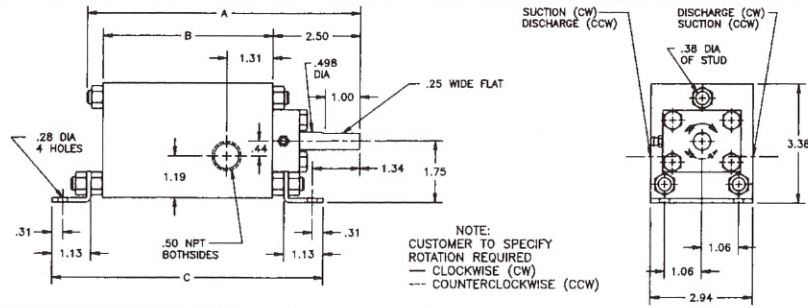

# DIMENSION DATA – MODEL 4400 THRU 4900

TAPPED CONNECTIONS  
(also available with  
Flanged Connections)

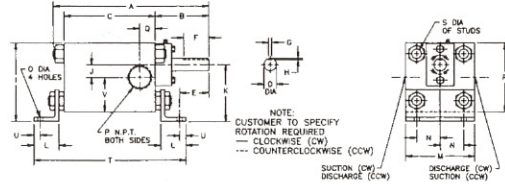

PUMP SIZE	DIMENSIONS IN INCHES																			Approx Weight Lbs.			
	A	B	C	D	E	F	G	H	I	J	K	L	M	N	O	P	Q	R	S		T	U	V
4400-05	9.44	3.25	5.63	.623	1.66	1.25	3/16	3/32	4.56	.63	3.13	1.75	4.00	1.31	.41	3/4	.97	4.00	.56	9.81	.50	2.00	27
4400-07	9.69	3.25	5.88	.623	1.66	1.25	3/16	3/32	4.56	.63	3.13	1.75	4.00	1.31	.41	3/4	.97	4.00	.56	10.06	.50	2.00	28
4400-10	9.94	3.25	6.13	.623	1.66	1.25	3/16	3/32	4.56	.63	3.13	1.75	4.00	1.31	.41	3/4	.97	4.00	.56	10.31	.50	2.00	29
4400-15	10.44	3.25	6.63	.623	1.66	1.25	3/16	3/32	4.56	.63	3.13	1.75	4.00	1.31	.41	3/4	.97	4.00	.56	10.81	.50	2.00	30
4500-05	9.94	3.50	5.81	.747	1.63	1.50	3/16	3/32	5.00	.75	3.50	2.00	4.50	1.50	.41	1	.84	4.50	.63	10.56	.50	2.25	33
4500-07	10.19	3.50	6.06	.747	1.63	1.50	3/16	3/32	5.00	.75	3.50	2.00	4.50	1.50	.41	1	.84	4.50	.63	10.81	.50	2.25	36
4500-10	10.44	3.50	6.31	.747	1.63	1.50	3/16	3/32	5.00	.75	3.50	2.00	4.50	1.50	.41	1	.84	4.50	.63	11.06	.50	2.25	37
4500-15	10.94	3.50	6.81	.747	1.63	1.50	3/16	3/32	5.00	.75	3.50	2.00	4.50	1.50	.41	1	.84	4.50	.63	11.56	.50	2.25	39
4600-05	11.69	4.25	6.69	.997	2.31	2.00	1/4	1/8	5.75	1.00	4.00	2.00	5.50	1.88	.41	1 1/2	1.22	5.50	.75	11.56	.50	2.75	51
4600-07	11.94	4.25	6.94	.997	2.31	2.00	1/4	1/8	5.75	1.00	4.00	2.00	5.50	1.88	.41	1 1/2	1.22	5.50	.75	11.81	.50	2.75	53
4600-10	12.19	4.25	7.19	.997	2.31	2.00	1/4	1/8	5.75	1.00	4.00	2.00	5.50	1.88	.41	1 1/2	1.22	5.50	.75	12.06	.50	2.75	56
4600-15	12.69	4.25	7.69	.997	2.31	2.00	1/4	1/8	5.75	1.00	4.00	2.00	5.50	1.88	.41	1 1/2	1.22	5.50	.75	12.56	.50	2.75	61
4600-20	13.19	4.25	8.19	.997	2.31	2.00	1/4	1/8	5.75	1.00	4.00	2.00	5.50	1.88	.41	1 1/2	1.22	5.50	.75	13.06	.50	2.75	66
4800-10	15.19	5.00	9.31	1.371	2.75	2.50	3/8	3/16	8.50	1.50	6.00	2.50	6.00	2.00	.53	2	1.47	8.00	.88	15.31	.75	4.00	125
4800-15	15.69	5.00	9.81	1.371	2.75	2.50	3/8	3/16	8.50	1.50	6.00	2.50	6.00	2.00	.53	2	1.47	8.00	.88	15.81	.75	4.00	132
4800-20	16.19	5.00	10.31	1.371	2.75	2.50	3/8	3/16	8.50	1.50	6.00	2.50	6.00	2.00	.53	2	1.47	8.00	.88	16.31	.75	4.00	138
4900-10	18.28	6.00	11.30	1.875	3.89	2.50	1/2	1/4	12.50	2.00	8.63	2.50	15.00	5.50	.94	2	1.50	11.75	.88	17.27	.88	5.88	335
4900-20	19.28	6.00	12.30	1.875	3.89	2.50	1/2	1/4	12.50	2.00	8.63	2.50	15.00	5.50	.94	2	1.50	11.75	.88	18.27	.88	5.88	363

# FLANGED CONNECTIONS

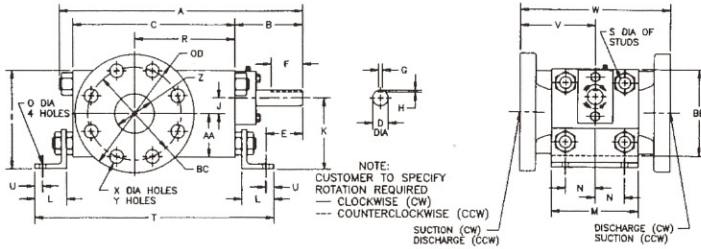

PUMP SIZE	DIMENSIONS IN INCHES																			Approx Weight Lbs.									
	A	B	C	D	E	F	G	H	I	J	K	L	M	N	O	R	S	T	U		V	W	X	Y	Z	OD	BC	AA	BB
4400-20	10.94	3.25	7.13	.623	1.66	1.25	3/16	3/32	4.56	.63	3.13	1.75	4.00	1.31	.41	4.25	.56	11.31	.50	3.50	7.00	.75	4	1.00	4.88	3.50	2.00	4.00	38
4400-25	11.44	3.25	7.63	.623	1.66	1.25	3/16	3/32	4.56	.63	3.13	1.75	4.00	1.31	.41	4.55	.56	11.81	.50	3.50	7.00	.75	4	1.25	5.25	3.88	2.00	4.00	40
4500-20	11.44	3.50	7.31	.747	1.63	1.50	3/16	3/32	5.00	.75	3.50	2.00	4.50	1.50	.41	4.00	.63	12.06	.50	4.00	8.00	.75	4	1.25	5.25	3.88	2.25	4.50	51
4500-25	11.94	3.50	7.81	.747	1.63	1.50	3/16	3/32	5.00	.75	3.50	2.00	4.50	1.50	.41	4.25	.63	12.56	.50	4.00	8.00	.88	4	1.50	6.13	4.50	2.25	4.50	55
4600-25	13.69	4.25	8.69	.997	2.31	2.00	1/4	1/8	5.75	1.00	4.00	2.00	5.50	1.88	.41	5.06	.75	13.56	.50	4.75	9.50	.75	8	2.00	6.50	5.00	2.75	5.50	85
4600-30	14.19	4.25	9.19	.997	2.31	2.00	1/4	1/8	5.75	1.00	4.00	2.00	5.50	1.88	.41	5.31	.75	14.06	.50	4.75	9.50	.88	8	2.50	7.50	5.88	2.75	5.50	91
4800-25	16.69	5.00	10.81	1.371	2.75	2.50	3/8	3/16	8.50	1.50	6.00	2.50	6.00	2.00	.53	6.06	.88	16.81	.75	5.75	11.50	.88	8	2.50	7.50	5.88	4.00	8.00	165
4800-30	17.19	5.00	11.31	1.371	2.75	2.50	3/8	3/16	8.50	1.50	6.00	2.50	6.00	2.00	.53	6.31	.88	17.31	.75	5.75	11.50	.88	8	3.00	8.25	6.63	4.00	8.00	177
4800-40	18.19	5.00	12.31	1.371	2.75	2.50	3/8	3/16	8.50	1.50	6.00	2.50	6.00	2.00	.53	6.81	.88	18.31	.75	5.75	11.50	.88	8	3.00	8.25	6.63	4.00	8.00	188
4800-50	19.19	5.00	13.31	1.371	2.75	2.50	3/8	3/16	8.50	1.50	6.00	2.50	6.00	2.00	.53	7.31	.88	19.31	.75	5.75	11.50	.88	8	4.00	10.00	7.88	4.00	8.00	207
4800-60	20.19	5.00	14.31	1.371	2.75	2.50	3/8	3/16	8.50	1.50	6.00	2.50	6.00	2.00	.53	7.81	.88	20.31	.75	5.75	11.50	.75	8	4.00	9.00	7.50	4.00	8.00	215
4900-35	20.78	6.00	13.80	1.875	3.89	2.50	1/2	1/4	12.50	2.00	8.63	2.50	15.00	2.00	.94	7.53	.88	19.77	.88	7.75	15.50	.88	8	4.00	10.00	7.88	5.88	11.75	476
4900-50	22.28	6.00	15.30	1.875	3.89	2.50	1/2	1/4	12.50	2.00	8.63	2.50	15.00	2.00	.94	8.28	.88	21.27	.88	7.75	15.50	.88	12	6.00	12.50	10.63	5.88	11.75	525

Not to be used for construction purposes unless certified.